



BOAT LIFT BOSS INSTALLATION GUIDE

FOR

Newmans, Hewitt, Ridgeline, Shoremaster, Pier Pleasure,

Beach King and Dockrite

PART NUMBER - 3001.2086

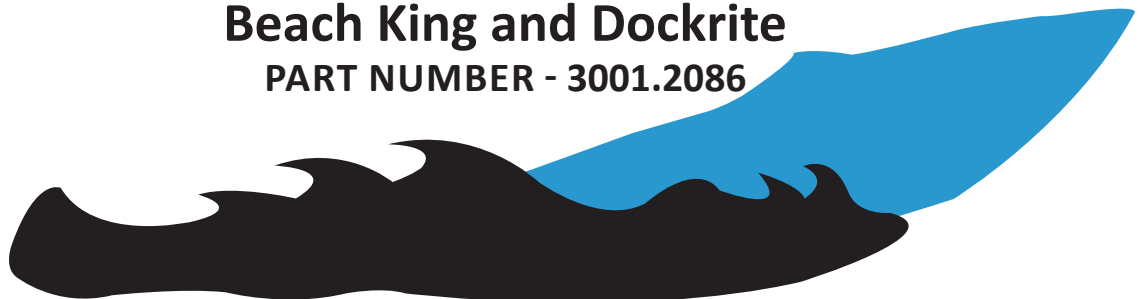

Extreme Max

6800 Otter Lake Road Lino Lakes, MN 55038

www.extrememax.com

Tech Support: 651-357-1862

BEFORE YOU BEGIN, READ AND UNDERSTAND ALL INSTRUCTIONS AND WARNINGS.

Contents of Main Box:

- 1) Boat Lift Boss drive assembly (motor, gear head, control box) weather proof cover and tear drop mount.
- 2) Keys
- 1) Wire harness with battery ring terminal connectors (12 volt models only)
- 1) Wireless remote (remote control models only)
- 1) Emergency backup and installation tool

Contents of Installation Kit:

- 1) Hardware bag #2
- 1) Aluminum torque arm #2
- 1) Drive shaft with lock cap
- 1) Instructions

Tools required for Installation:

- Adjustable wrench (or channel lock pliers)
- 9/16" socket with ratchet
- 9/16" wrench
- 3/4" socket
- 1/2" socket
- 10mm wrench
- Cordless drill
- Grease
- Lubricant such as WD-40 (for old wheel removal)

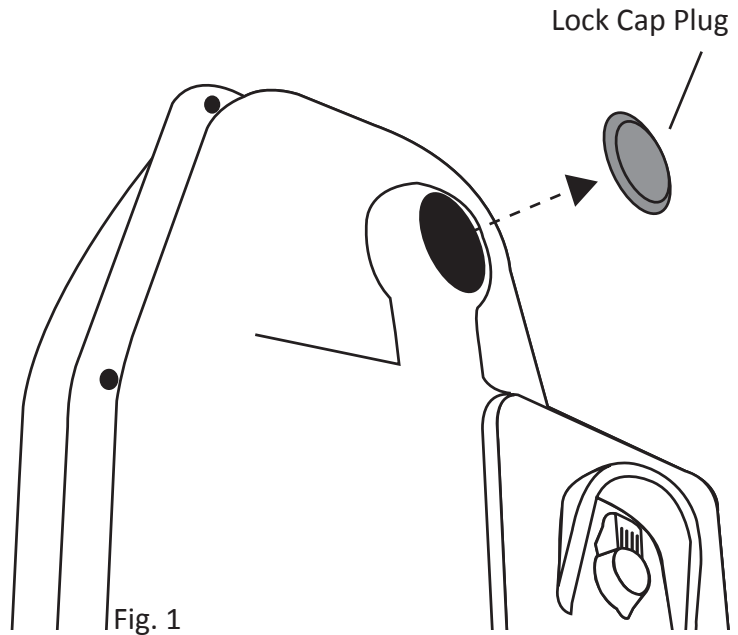

Prepare the Boat Lift Boss for Installation

Congratulations on your purchase of the Boat Lift Boss. You are about a half hour away from the joy of quiet and effortless boat lift operation.

Remove Boat Boss from main box and remove lock cap plug. (Fig. 1)

Remove the drive shaft and lock cap assembly from the installation kit.

Apply grease to the outside threads of the shaft. (Fig. 2)

Install the drive shaft by threading into the gear head from the back side and tighten. (Fig. 2)

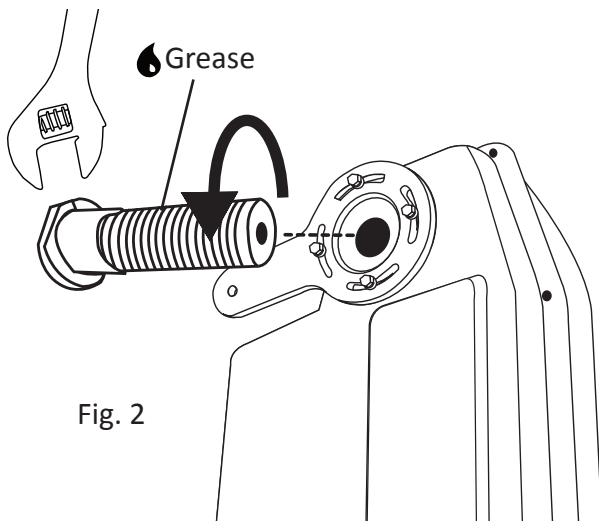

If there are any missing or damaged parts, **do not** return the Boat Lift Boss to the retailer where you purchased it.

Call our Boat Boss Service Dept. @ 651-357-1862

e-mail - sales@extrememax.com

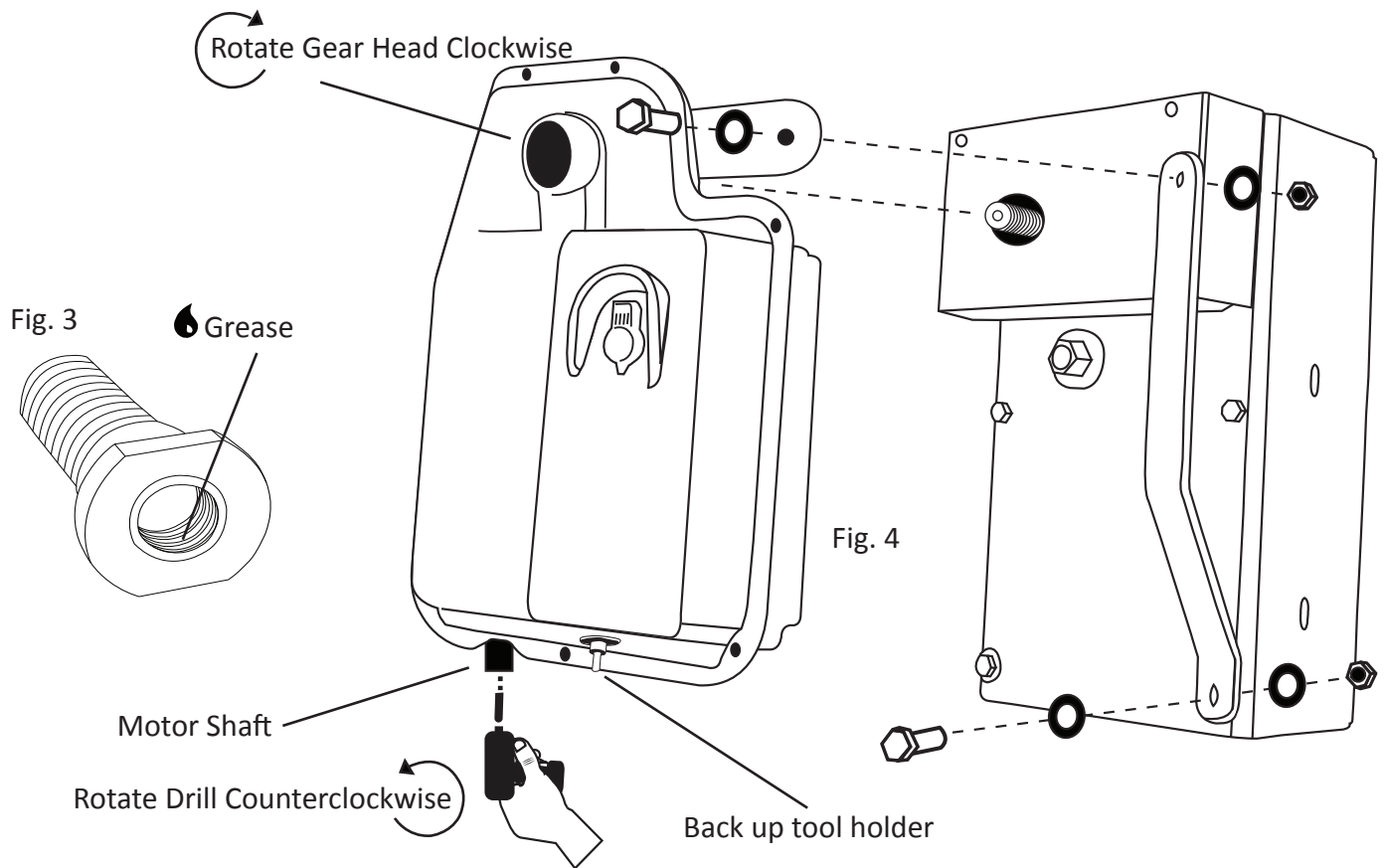

****Use cordless drill and emergency back up drive tool for the installation to the winch box.***

Lower your boat lift cradle to its lowest position, until there is no tension on the cable. Secure your boat with a rope so it doesn't float away.

Remove the wheel from your boat lift. If your lift is not new you may use a liquid penetrant, such as WD-40 or Liquid Wrench. Remove the cover to access the ratchet mechanism on your boat lift winch. Hold the winch box drive shaft with a pipe wrench allowing you to remove the wheel. Remove or disable the ratcheting system which is no longer needed with the Boat Lift Boss system. Reinstall any covers that were removed.

Apply grease to the inside threads of Boat Lift Boss drive shaft. (Fig. 3)

In this next step a second person would be helpful, but not necessary. Place the drive unit on the threads of the winch box and slide the cordless drill with the emergency back up tool over the drive stub on the bottom of the motor.

Set the drill for counterclockwise rotation, causing the drive gear head to spin clockwise, and thread the gear head into place. (Fig. 4)

Caution: Do not attempt to lift the boat or cradle at this time.

If there are any missing or damaged parts, do not return the Boat Lift Boss to the retailer where you purchased it.

Call our Boat Boss Service Dept. @ 651-357-1862

e-mail - sales@extrememax.com

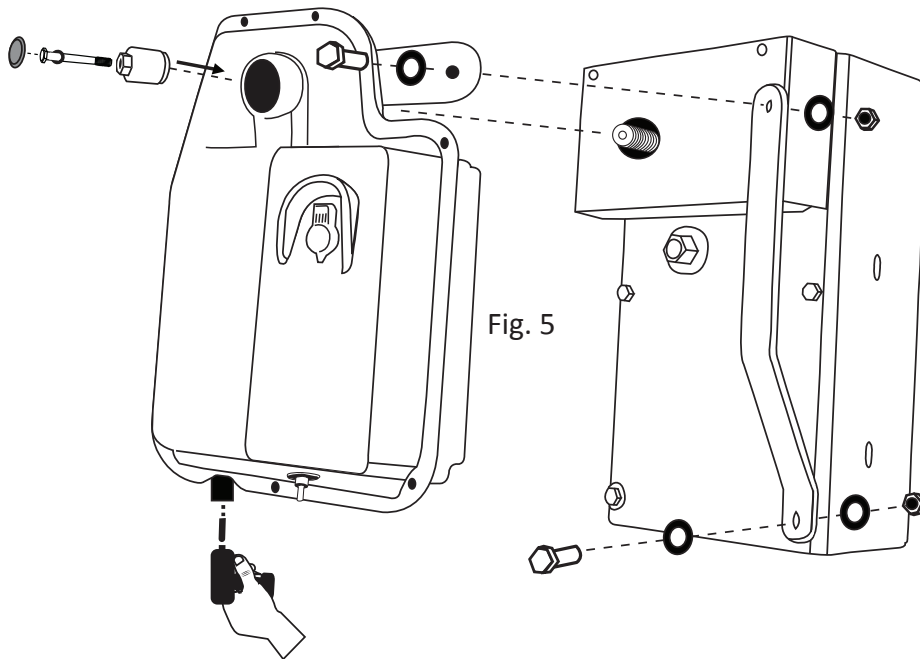

Fig. 5

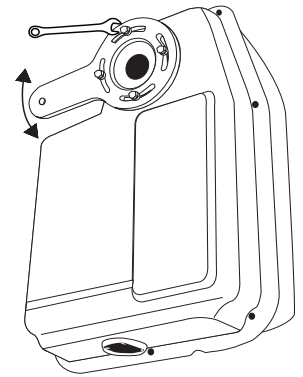

Fig. 6

Install the top of the torque arm to the tear drop bracket on power unit and fasten using the 3/8" x 1 1/4" bolt, 2 flat washers, and 3/8" lock nut. Locate the 3/8" bolt (9/16" head) on the front bottom right of the winch box and fasten the lower end of the aluminum torque arm to the winch box using the 3/8" x 1 1/4" bolt, 2 flat washers, and lock nut supplied and tighten. (Note: some applications will require you to drill a 3/8" hole in this location) (Fig. 5)

Next you will need to adjust the drive unit so that it is vertical and straight. To do this you will need to use a 10mm wrench to loosen the 4 bolts on the tear drop bracket and adjust. Retighten the 4 bolts carefully and evenly to approximately 5 foot pounds of torque. (Fig 6)

Read and understand the [User's Guide](#) on the next page. Plug the Boat Lift Boss into a ground fault protected outlet on 120 volt models. On 12 volt models, connect the positive and negative cables to a 12 volt battery. You can also connect the Boat Lift Boss to your boat battery by purchasing the optional wire extension kit. (Part # 3001.2123)

Use the key to lift the cradle of the boat lift to apply tension on the cable so that power unit threads all the way into place. Make sure that the cable is winding on the spool properly.

Install the aluminum lock cap on the drive shaft and tighten with a 3/4" socket.

Install 5/16 bolt and washer through lock cap into the drive shaft and tighten. (Fig. 5)

Untie your boat and position it on the lift. Check to make sure that lifting is done with the gear head running in the clockwise direction. Lift your boat.

After a few uses, re-check all fasteners for tightness.

Install lock cap plug to the hole in the all weather cover.

If there are any missing or damaged parts, do not return the Boat Lift Boss to the retailer where you purchased it.

Call our Boat Boss Service Dept. @ 651-357-1862

e-mail - sales@extrememax.com

USER'S GUIDE

User tips for all models:

Extra Caution: At this time it is important to check that lifting can only be done when the gear head is going in a clockwise direction. If you attempt to try to lift in a counter-clockwise direction, the unit may unscrew from the winch box, possibly causing serious damage or injury. If you have questions or do not understand this procedure, **STOP**, and call the Boat Boss Service Dept. @ 651-357-1862 between 8:00 A.M. and 5:00 P.M. Central Time Monday - Friday.

Do not overload the capacity of your lift or drive system. When lifting, do not over lift, or let the cradle or pulleys make contact with the lift frame. Serious damage or injury could occur.

When lowering your lift, go down just far enough so the boat will come off of the lift. If you run the system too long in the down cycle, the cable will wind backwards and lift the boat, which could cause serious damage or injury.

Put one of the two keys on a floating key chain and the spare key in a safe place.

Located on the bottom of the all weather cover is an emergency backup drive tool, included to raise and lower your boat in case of power outage or system failure.

WARNING: Do not let anyone under the age of 18 operate the Boat Lift Boss system.

STORM WARNING: In the event of an impending storm, unplug your Boat Boss, not doing so could result in damage to the Boat Boss electrical box.

User tips for 120 volt models:

WARNING: Be sure to use with a professionally installed ground fault interrupter. Failure to do so could result in injury or death. Ask your electrician for power and wiring requirements. If the distance between your power supply and Boat Lift is over 50 feet, a 10 ga. wire is recommended.

After all of the mechanical installation tasks are completed and all electrical connections are performed properly, your system is ready to use.

User tips for 12 volt models:

The red connector can be pulled apart in case of emergency to disable the system.

After all of the mechanical installation tasks are completed and all electrical connections are performed properly, your system is ready to use.

User tips for remote control models:

Never attempt to use the key switch and the remote control at the same time. We suggest not having the key in the control box when you plan to use the remote control.

Your remote range will vary depending upon land topography and ground clutter (trees, buildings, etc.).

Do not use your remote from more than 15 feet from your lift. This will prevent accidentally exceeding the travel limits of your boat lift and allow you to properly monitor the operation of your Boat Lift Boss. Never operate the remote out of visual contact. Severe injury or damage could occur.

Available Accessories

- Battery Holder – Canopy Mounted
- Battery Holder – Lift Frame Mounted
- 12 Volt Charging System – Solar Panel and Mount
- 12 Volt Power Extension Cables

**EXTREME MAX
PRODUCTS**