

## IMPORTANT INFORMATION

**Before installation, read and understand all instructions and warnings.  
All 120 Volt units MUST have electrical ground fault interrupter protection.**

### **Warning:**

Hazardous voltage. Contact may cause electrical shock and injury. Disconnect before servicing.

- Misuse of this product can result in bodily injury, death, or property damage.
- Do not overload the capacity of the lift or drive system. When lifting, do not let the cradle or pulleys make contact with the lift frame. Serious injury or damage could occur.
- When lowering the lift, go down just far enough so the boat will come off of the lift. Running the system too long in the down cycle will wind the cable backwards and lift the boat, which could cause serious injury or damage.
- To prevent serious personal injuries or death, do not allow children, swimmers or pets on or near the boat or lift while it is in operation as they may become caught under the boat and suffer pinch, amputation or other serious injuries.
- In the event of unintentional or erratic operation permanently unplug unit from power source to disable the system and contact the Extreme Max service department at 651-357-1862.

### **120 Volt Models**

120-Volt Boat Lift Boss models must only be used on an electrical circuit that has ground fault interrupter protection. The interrupter and its supply circuit **MUST** be installed to all applicable electrical codes. Any necessary electrical work should be done by a licensed electrician. Boat Lift Boss should only be connected to power source by a marine-rated, 3-prong grounded cord. Cord should be inspected regularly to insure good condition. Improper wiring or lack of a properly installed ground fault interrupter poses a high risk of injury or death.

### **Caution:**

#### **120 Volt Models**

If the unit will be left unattended, disconnect the unit from power source to prevent damage from lightning and electrical surges.

#### **12/24 Volt Models**

If the unit will be left unattended, disconnect the unit from the power source or move the power switch to the "OFF" position to prevent damage.

#### **Remote Control Models**

Never attempt to use the key switch and the remote control at the same time. Do not have the key in the control box when you plan to use the remote control to prevent property damage.

## **Instructions**

- Read all instructions and warnings prior to installation and use.
- For use by adults over age 18.
- Wait for the motor to come to a complete stop before changing directions.
- Do not lift anything other than your boat.
- Put one of the two keys on a floating key chain and the spare key in a safe place.

#### **Remote Control Models**

- Remote range will vary depending upon land topography and ground clutter (trees, buildings, etc.).
- Do not use remote more than 15 feet (4.5m) from the lift. This will prevent accidentally exceeding the travel limits of the boat lift. Never operate the remote out of visual contact.

**Loop the electrical cord connection as shown to help secure connection.**

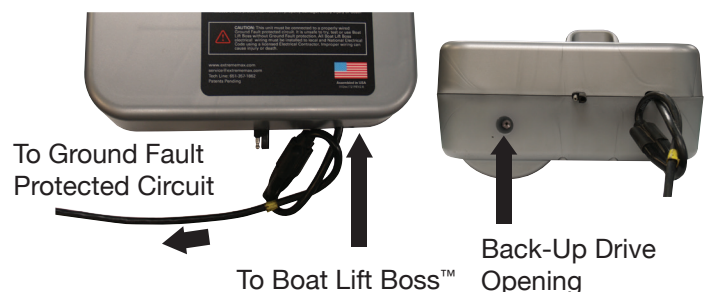

# Congratulation! You're minutes away from the convenient and quiet operation of Boat Lift Boss™.

## Tools Required for Installation

- 9/16" (1.42cm) socket with ratchet
- 9/16" (1.42cm) wrench
- 10mm wrench (optional)

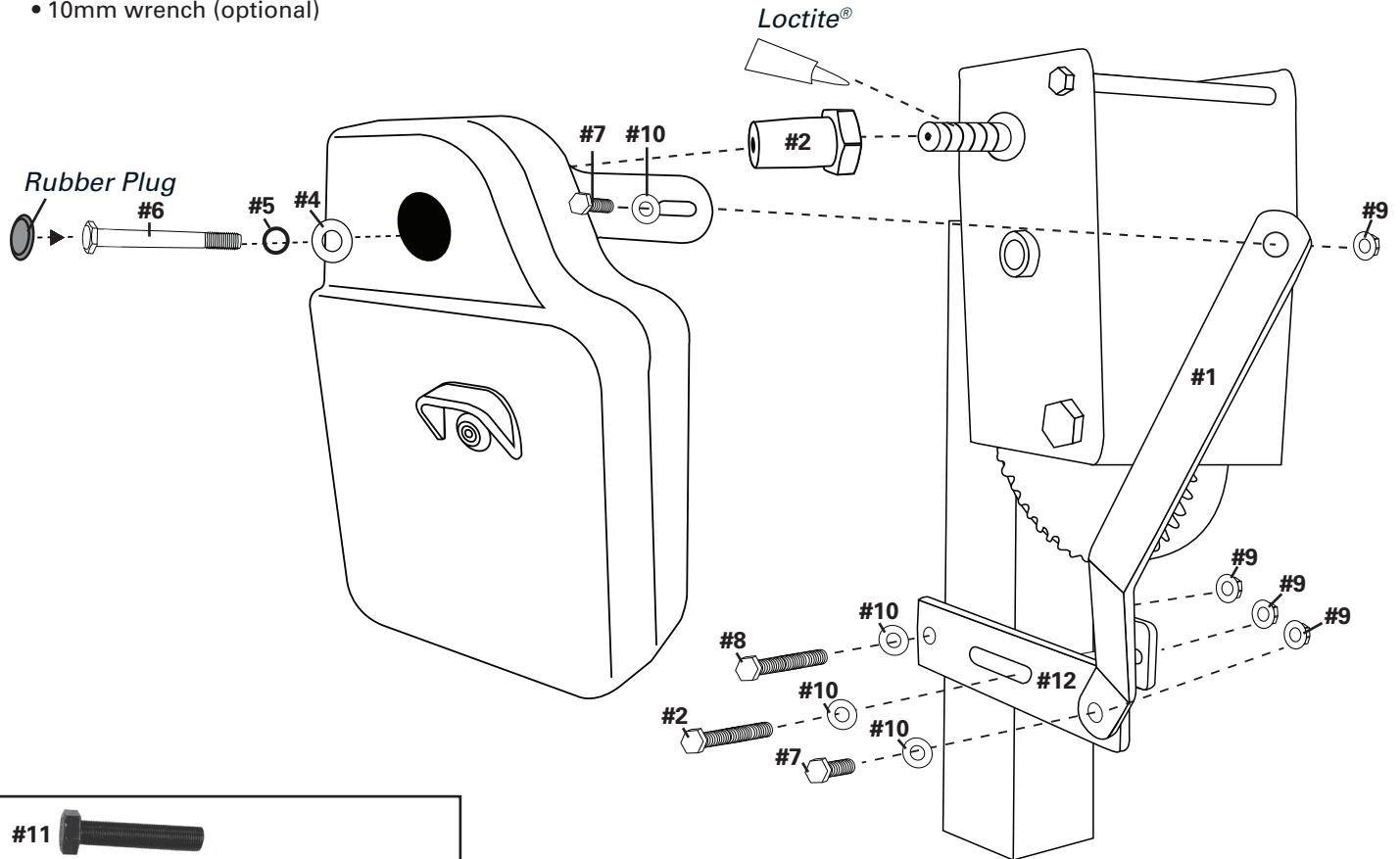

**#11**  
**Important:** The Puller Bolt is not used for installation. It is required for uninstalling your Boat Lift Boss. Please put the Puller Bolt in a safe place. Instructions can be found on the Boat Lift Boss™ Maintenance & Service sheet in the motor packaging box.

## Installation Kit Contents:

Qty.	Description	No.
1	Instruction Sheet	
1	Torque Arm	#1
1	Tapered Drive Shaft	#2
1	Loctite®	#3
1	Hardware Kit (1103.1203)	
1	3/8" x 1-1/4" (0.95cm x 3.17cm) Diameter Thick Fender Washer	#4
1	3/8" (0.95cm) Lock Washer	#5
1	3/8" x 2-3/4" (0.95cm x 6.98cm) Main Mounting Bolt, 24 Pitch	#6
2	3/8" x 1-1/4" (0.95cm x 3.17cm) Stainless Steel Bolt	#7
2	3/8" x 4-1/2" (0.95cm x 11.43cm) Full Thread Bolt	#8
4	3/8" (0.95cm) Serrated Flange Head Lock Nut Stainless	#9
8	3/8" (0.95cm) Flat Washer Stainless	#10
1	5/8" x 3" (1.58cm x 7.62cm) Hardened Tap Bolt, 18 Pitch Puller	#11

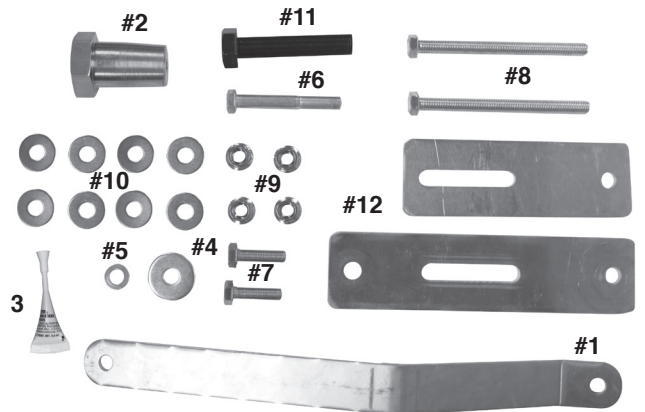

# Boat Lift Boss™ Installation

## Step 1 - Lift Cradle Positioning

Lower the boat lift cradle to its lowest position until there is no tension on the cable. Secure boat with rope so it doesn't float away.

## Step 2 - Removing the Wheel & Braking System

To remove the wheel from the boat lift, remove the fastener from the center of the wheel. Turn the wheel counterclockwise until it unthreads from the winch box.

If the winch is equipped with a brake that makes an audible clacking sound, it needs to be unbolted and removed.

This is the current braking system on the winch box and **MUST** be removed or disabled or damage may occur. Boat Lift Boss™ has a built-in braking system.

Remove 7/8" Bronze Washer from winch input shaft and save for future use if a hand wheel is required.

## Step 3 - Installing Boat Lift Boss™

Apply Loctite® to the threads on the input shaft of the winch. Thread the tapered drive stub (#2) to the lift and hand tighten. Push the Boat Lift Boss™ drive on to the tapered shaft.

Secure by using the 3/8" x 2-3/4" (0.95cm x 6.98cm) bolt (#6), lock washer (#5) and 3/8" x 1-1/4" (0.95cm x 3.17cm) diameter thick fender washer (#4).

Hand tighten with 3/8" (0.95cm) ratchet and 9/16" (1.42cm) socket to approximately 20 foot lbs of torque (2.76 kgF) (Do not over tighten.)

## Step 4 - Final Connections & Adjustments

Assemble the two piece lower clamp around the lift's vertical upright by using two 3/8" (0.95cm) bolts (#8), four 3/8" (0.95cm) flat washers (#10), and two 3/8" (0.95cm) lock nuts (#4).

Attach the bottom of the long torque arm to the two piece bracket and Boat Lift Boss™ bracket using two 3/8" x 1-1/4" (0.95cm x 3.17cm) bolts (#7), four 3/8" (0.95cm) flat washer (#10) and 3/8" (0.95cm) lock nut (#9).

Adjust the two piece bracket (up or down) level the Boat Lift Boss™ housing. Tighten bolts securely.

Check all fasteners and make final adjustments.

## Attention:

*At this time it is important to check that lifting can only be done when the gear head goes in a clockwise direction. Attempting to lift in a counter-clockwise direction may unscrew the unit from the winch box, causing serious damage or injury. If you have questions or do not understand this procedure -STOP- and call the Boat Lift Boss™ Service Department at 651-357-1862 between 8:00 A.M. and 5:00 P.M. Central Standard Time, Monday - Friday or e-mail [boatliftboss@extrememax.com](mailto:boatliftboss@extrememax.com).*

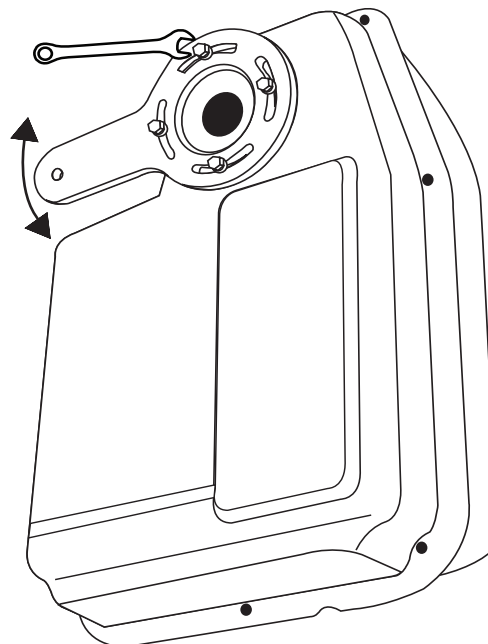

**After all connections use a 10 mm wrench to adjust and straighten if necessary.**

## Contents:

Qty. Description

- 1 - Boat Lift Boss™
- 2 - Keys
- 1 - Wire harness with battery ring terminal connectors (12 volt models only)
- 1 - Wireless remote (Remote control models only)

## Maintenance

Inspect Boat Lift Boss™ and electrical connections regularly to insure that all parts

## Storage

Cover Boat Lift Boss™ to prevent damage from snow, rain, ice, and UV rays.

## Back-Up Drive

During power outage, use a drill with a 1/4" extension and a 7/16" or 1/2" socket on the bottom of the motor shaft. Counter-clockwise lifts boat and clockwise lowers boat.

## Removal

- 1) Completely lower the lift rack so there is no tension on the winch cable.
- 2) To remove Boat Lift Boss™ for service, use the puller supplied with the hardware kit.
- 3) Remove the rubber plug and 3/8" mounting bolt and washer.
- 4) Use a ratchet with a 15/16" socket to install puller bolt into the threads located behind the black plug.
- 5) Hand tighten the threaded bolt. With the socket wrench, tighten 1/4 to 1/2 turn or until Boat Lift Boss™ separates from the boat lift.

3/8" Mounting Bolt

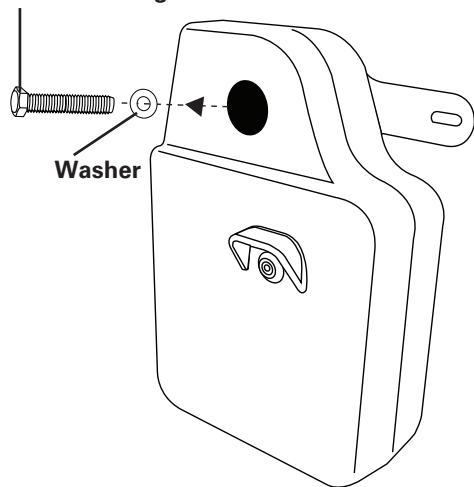

Washer

Puller Bolt

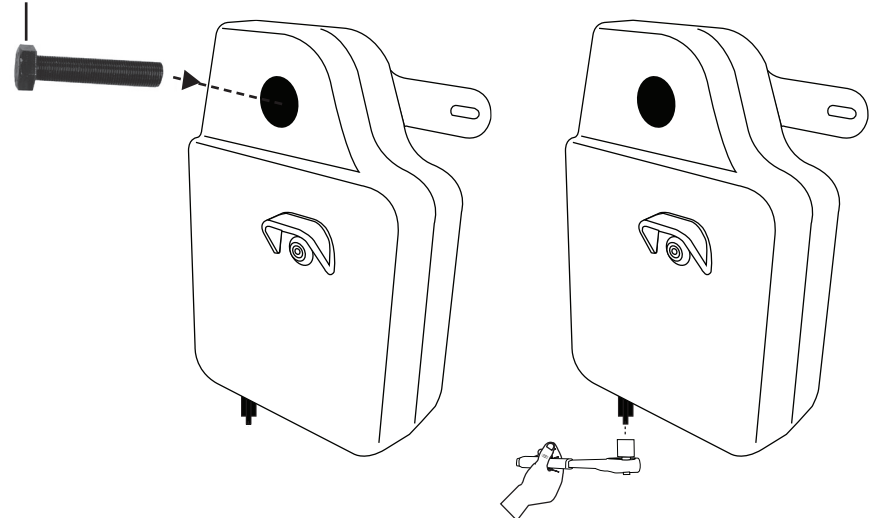

# If there are any missing or damaged parts, DO NOT return Boat Lift Boss™ to the retailer.

Call the Boat Lift Boss™ Service Dept. at: 651-357-1862

E-mail - boatliftboss@extrememax.com

## Limited Warranty

Extreme Max™ Boat Lift Boss™ Direct Drive Systems are conditionally warranted for consumer use for 2 years after the date of retail purchase. Warranty valid only in the USA and Canada.

Extreme Max™ Boat Lift Boss Direct Drive Systems are conditionally warranted to the original retail purchaser to be free from defects in material and workmanship, ordinary wear and tear expected. This warranty shall not apply to any defects caused by (I) overloading, (II) physical abuse of goods or any acts of vandalism by any person, (III) improper installation or use contrary to the instructions, (IV) commercial use, (V) saltwater use. The sole remedy under this warranty is at the discretion of the manufacturer: the repair of the product by the manufacturer at the manufacturer's facility, or the replacement of the same or similar product. Extreme Max™ is not responsible for any consequential or incidental damages. The consumer shall be responsible for shipping charges to return any unit believed to be defective to Extreme Max™. Repaired or replacement units shall be returned to the consumer at the manufacturer's expense. In the event that a unit is not defective, it will be returned to the consumer at the consumer's expense. Any and all expedited freight charges to handle warranty claims are the responsibility of the consumer. Extreme Max™ is not responsible for any 3rd party labor charges that may be incurred in removing, transporting or installing the lift.

Extreme Max™ disclaims any other express warranties, all UCC implied warranties, and warranties of merchantability and fitness for purpose.

To expedite warranty service, please complete and return the Warranty Registration Card along with a copy of original retail sales receipt at the time of purchase.

To submit a warranty claim, please send your name, mailing address, original sales receipt and summary of alleged defect to boatliftboss@extrememax.com. Please e-mail or call (651) 357-1862 with questions regarding warranty service and claims.

Boat Lift Boss Installation Guide for  
Dutton Lainson, Dutton Lainson  
DLB 2500 "Floe, Shelby, and Fulton  
Boat Lifts

PART #: 3005.7231, 3005.7228,  
3005.7231, 3005.7237

3007.2129

